

Healthweigh™ Bariatric/Handrail Scales



Model 240-10

Standard Features

- Capacity: 700lb x 0.2lb (310kg x 0.1kg)
- Platform dimensions: 20" x 25" x 3"
- Handrails for extra support and safety
- Integrated wheels for ease of portability
- Large 1" LCD display
- Low battery indicator/automatic power-off
- BMI (body mass index) function
- Reweigh function
- Hold function
- Unit of measure: lb only, kg only, lb/kg
- RS-232 output
- Updatable firmware

Specifications

POWER:

9 VDC, provided by AC adaptor or internal rechargeable battery

BATTERY TYPE:

Sealed lead acid

BATTERY USE:

75 hours

Automatic power-off can be configured from 0-20 minutes

OPERATING TEMPERATURE:

50°F to 104°F (14°C to 40°C)

APPROVALS:

OIML
Class III (EU)
CE

WARRANTY:

Two-year limited warranty

DIMENSIONS

A: 20"	D: 25"
B: 25"	E: 34"
C: 3"	F: 44.5"

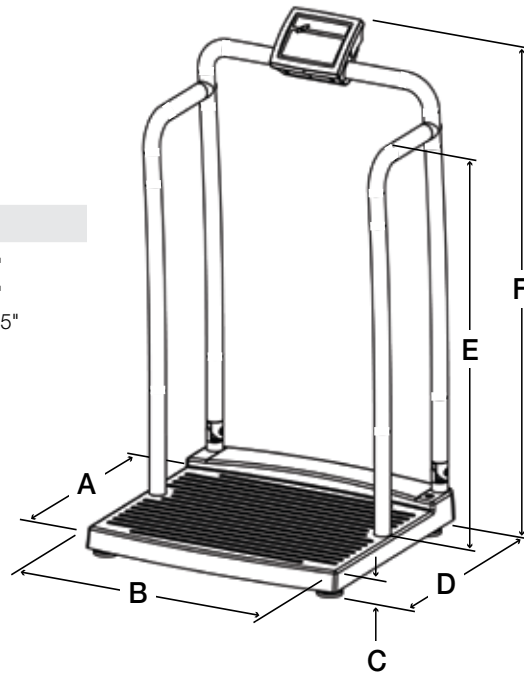

Bariatric/Handrail scale indicator