



RE Series Price Computing Scale



RE-C (with Tower) Model



RE Model

1.	INTRODUCTION.....	2
2.	INSTALLATION	2
2.1	Unpacking	2
2.2	Assembling.....	2
2.3	Selecting the Location.....	3
2.4	Leveling the Scale.....	3
2.5	Connecting Power.....	3
3.	OVERVIEW OF CONTROLS AND FUNCTIONS.....	5
3.1	Control Panel	5
3.2	Customer Display	5
3.3	Keys and Display Indicators.....	6
4.	OPERATIONS.....	7
4.1	Turning the Unit On and Off.....	7
4.2	Backlight Operation.....	7
4.3	Zero Operation.....	7
4.4	Manual (Pushbutton) Tare.....	7
4.5	Pre-set (Keyboard) Tare	7
4.6	Weighing and Pricing	8
4.7	Hold Function.....	8
4.8	Pre-pack Weighing Function	8
4.9	PLU Function (Price Lookup).....	9
4.10	By-Count Function	10
4.11	Accumulation (Totalize) Function.....	10
4.12	Fractional Pricing.....	11
5.	SCALE SETTINGS.....	12
5.1	Accessing the User Setup Mode	12
5.2	User Setup Parameters	12
6.	CALIBRATION AND SEALING	13
6.1	Calibration	13
6.2	Type Approval Sealing.....	15
7.	TROUBLESHOOTING	16
7.1	Cleaning.....	16
7.2	Troubleshooting.....	17
8.	TECHNICAL DATA	18
8.1	Specifications.....	18
8.2	Drawings.....	19
8.3	Compliance	20
	LIMITED WARRANTY	21

1. INTRODUCTION

This manual contains installation, operation and maintenance instructions for the RE Series scale. Please read the manual completely before installation and operation.

Safety Precautions



For safe and dependable operation of this scale, please comply with the following safety precautions:

- Verify that the input voltage printed on the AC Adapter and the plug type matches the local AC power supply.
- Make sure that the power cord does not pose an obstacle or tripping hazard.
- Disconnect the scale from the power supply when cleaning the scale.
- Do not operate the scale in hazardous or unstable environments.
- Do not drop loads on the platform.
- Use only approved accessories and peripherals, as available.
- Operate the scale only under ambient conditions specified in these instructions.
- Service should be performed by authorized personnel only.

2. INSTALLATION

2.1 Unpacking

Unpack and verify that the following components have been included:

- Scale Unit
- Weighing Pan
- Power Adapter
- Instruction Manual
- Tower assembly (tower models only)

Save the packaging material. This packaging ensures the ideal protection for the storage or transport of the product.

2.2 Assembling

For tower models only, install the tower display first by removing the retaining screw at the bottom of the tower, and the bottom plate of the tower bracket at the back of the scale. Route the connector through the tower bracket before mounting the tower, plug the connector into the bottom socket, affix the tower to the bracket, then re-install the bottom plate of the tower bracket.

Install the weighing pan as illustrated below, with the pan properly aligned.

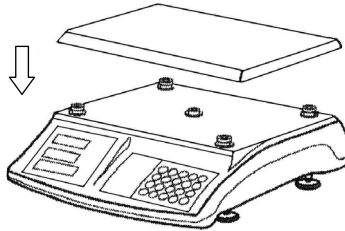

2.3 *Selecting the Location*

Operate the scale on a firm, level surface. Avoid locations with rapid temperature changes, excessive air currents, vibrations, electromagnetic fields, heat or direct sunlight.

2.4 *Leveling the Scale*

Adjust the leveling feet until the bubble is centered in the circle of the level indicator (located on the front panel). Ensure that the scale is level each time its location is changed.

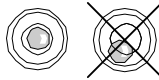

2.5 *Connecting Power*

2.5.1 *AC Power*

Verify that the intended AC power source matches the AC adapter rating. Connect the adapter to the power receptacle underneath and to the right of the scale, then plug the AC adapter into a properly grounded power outlet.





2.5.2 *Battery Operation*



Dispose of the batteries according to local laws and regulations.

This scale can operate with six D-size standard alkaline batteries (not included). To install, unplug the scale first from the power supply. Open the battery cover (located at the bottom of the scale) by gently depressing the two cover buttons, then install the batteries as illustrated on the battery holder. Re-close the cover by gently inserting it back into position and the two cover buttons snap into place.

When running on batteries, the battery cursor is displayed and indicates the state of the battery power:

	Battery is full
	About 2/3 battery power remaining
	About 1/3 battery power remaining
	Battery power is critical; batteries need to be changed

2.5.3 Battery Power Saving Feature

When powered on batteries, the scale will enter sleep mode (Weight display will show “*SLEEP*”, and Unit Price and Total Price displays will be blank) after the pre-set minutes of inactivity. It reactivates when a key is pressed or an item placed on the pan. The scale can also be set to power off automatically after the pre-set minutes of inactivity.

By default, these features are enabled. See Section 5.2 to disable these power saving functions.

3. OVERVIEW OF CONTROLS AND FUNCTIONS

3.1 Control Panel

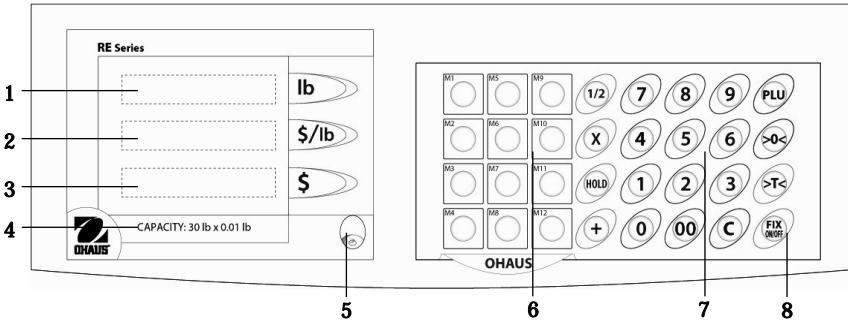

3.2 Customer Display

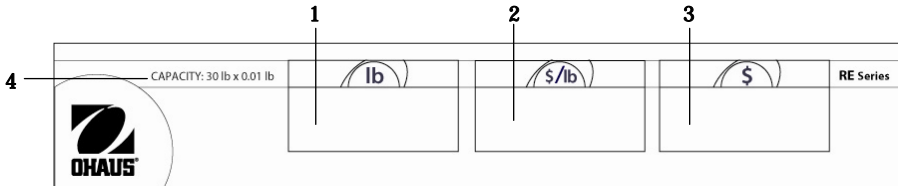

- 1 Weight display
- 2 Unit Price display
- 3 Total Price display
- 4 Weights & Measures marking
- 5 Leveling Indicator
- 6 Memory Keys / Pull-out Tab
- 7 Numeric Keypad
- 8 On/Off Key

3.3 Keys and Display Indicators



- Short press turns the scale on; long press turns the scale off
- Activates Pre-pack weighing; displayed Unit Price is fixed
- In SETUP Mode, accepts the displayed setting and proceeds to the next step



- Numeric keys to enter Unit Price, Tare, PLU number and Pre-set (keyboard) Tare



- Clears the keyboard input or Accumulation data



- Zeros the display
- In SETUP Mode, toggles back to the previous step



- Registers the weight of the object on the weighing pan as a Tare value
- In SETUP Mode, toggles through the available settings



- Adds displayed Total Price into Accumulation memory



- Activates the By-Count operation and calculates the price of the item



- Stores or recalls a PLU
- In SETUP Mode, ends the setup mode



- Holds the displayed Total Price when the item is removed from the pan



- Activates ¼ and/or ½ Fractional Pricing mode (as enabled in the Service Setup mode)

ZERO

- Indicates scale is at Center of Zero

PT

- Indicates keyboard Tare or tare recalled from PLU

NET

- Indicates Net (Gross minus Tare) value; push-button Tare exists

FIX

- Indicates Unit Price is fixed

X

- Indicates scale is in By-Count mode

1/2

- Indicates ½ lb pricing is activated

1/4

- Indicates ¼ lb pricing is activated

ADD

- Indicates scale is in Accumulation mode; data exists in Accumulation memory

TOTAL

- Indicates displayed Total Price is added into Accumulation memory



- Indicates battery operation and power level

4. OPERATIONS

4.1 Turning the Unit On and Off

Short-press [ON/OFF] to turn the scale on; long-press to turn the scale off. If a weight on the pan exceeds the power-on zero range ($\pm 10\%$ of the scale capacity), “-----” will be displayed. Remove the excess weight for the scale to capture zero. Ideally, allow 15~30 minutes for the scale to warm up before use.

4.2 Backlight Operation

With the scale on, press and hold [C] until the long beep. Upon release, the scale beeps twice and the backlight turns on (repeat this step to turn off, or when the scale is restarted). The backlight temporarily switches off after 15 seconds of inactivity, and reactivates with a key press or item placed on the pan.

4.3 Zero Operation

Press [$>0<$] to zero the displayed weight (the weight must be stable and within $\pm 2\%$ of the scale capacity). Center of Zero is indicated by the $>0<$ annunciator.

4.4 Manual (Pushbutton) Tare

4.4.1 Storing a Pushbutton Tare

Place an empty container on the pan, then press [$>T<$]. The Weight display will show a net value of “0.00”, and the NET annunciator will turn on. Remove the container, and the negative value displayed will be equivalent to the Tare weight.

4.4.2 Clearing a Pushbutton Tare

Press [$>T<$] with the pan empty.

4.5 Pre-set (Keyboard) Tare

4.5.1 Storing a Keyboard Tare

Enter the known Tare value (up to the scale capacity, and in increments of the scale readability) via the numeric keypad, then press [$>T<$]. The Weight

display will show the Tare as a negative net value (with the pan empty), and the *PT* and *NET* annunciators will turn on as the Tare weight is registered.

4.5.2 *Recalling a Keyboard Tare*

With the *PT* annunciator on, press [*>T<*]. “*Pt*” and the pre-set tare value are displayed. Press [*>T<*] again to return to normal weighing mode.

4.5.3 *Clearing a Keyboard Tare*

With the *PT* annunciator on, press [*>C<*].

4.6 *Weighing and Pricing*

Place the item to be weighed on the pan, then enter the Unit Price via the numeric keypad. The item weight will be shown in the Weight display, the unit price in the Unit Price display, and the resulting total price in the Total Price display.

The Unit Price and Total Price values are cleared automatically when the item is removed from the pan (Unit Price will be retained if the scale is in Pre-pack Mode – see Section 4.8).

4.7 *Hold Function*

After performing a price transaction (Section 4.6), press [*HOLD*] to keep the Total Price displayed (the *HOLD* annunciator will turn on). Press [*HOLD*] again to clear the display and return to normal weighing.

4.8 *Pre-pack Weighing Function*

When weighing and pricing items of the same price and/or tare value, enter these values only once with the Pre-pack function.

1. Enter the Unit Price, and/or Keyboard Tare value (Section 4.5.1).
2. Press [*FIX*]. The *FIX* annunciator will turn on.
3. Weigh and price items repeatedly without losing the Unit Price/Tare values.
4. When pre-pack weighing is finished, press [*C*] to clear the values and return to normal weighing.

4.9 PLU Function (Price Lookup)

The PLU function is used for quick storage and recall of the unit price and tare value of frequently sold goods. There are two ways to enter PLU data: a) via the PLU key, and b) via the Memory (M1...M12) keys.

4.9.1 PLU Function via the PLU Key

The unit price is looked up by simply entering the PLU number via the numeric keypad. The PLU function can store up to 100 PLU's.

4.9.1.1 Storing a PLU

1. Enter the Unit Price, and/or Keyboard Tare value (Section 4.5.1).
2. Press and hold *[PLU]* until the long beep. "PLU" will be displayed.
3. Enter the PLU number (1-100). The scale beeps twice, indicating that the PLU data was stored.

4.9.1.2 Recalling a PLU (with auto-PLU search function on – Sec. 5.2)

Enter the PLU number with the pre-stored data, then press *[PLU]*. The corresponding Unit Price/Tare value will be displayed.

4.9.1.3 Recalling a PLU (with auto-PLU search function off – Sec. 5.2)

Press *[PLU]*, then the PLU number with the pre-stored data. The corresponding Unit Price/Tare value will be displayed.

Note: If entering a PLU number with no stored data, "noPLU" will show momentarily in the Weight display.

4.9.2 PLU Function via the Memory Keys

The scale has 12 memory keys M1...M12 to store and recall up to 12 or 24 PLU's (depending on the setting in the setup mode -- Section 5.2). The M-keys can be used together with the pull-out tab (where the PLU information can be written for quick reference).

4.9.2.1 Storing a PLU into Memory

1. Enter the Unit Price, and/or Keyboard Tare value (Section 4.5.1).
2. Press and hold the desired *M-key* until the long beep (any pre-existing stored data in that memory location will be overwritten).

3. If set to store two PLU's per M-key, press and hold the desired *M-key* until the long beep, then quickly press the *M-key* again within 1 second. "L2" appears momentarily to indicate the data is stored in the second memory location of that M-key.

4.9.2.2 Recalling a PLU from the M-Key

1. Press the *M-key* with the pre-stored data. The corresponding Unit Price/Tare value will be displayed.
2. If set to store two PLU's per M-key, quick press the *M-key* twice within 1 second. "L2" appears momentarily, then the corresponding Unit Price/Tare value.

Note: If pressing an M-key with no stored data, "noPLu" will show momentarily in the Weight display.

4.10 By-Count Function

The By-Count function is used as reference to calculate the price of non-weighing items, e.g., the price for 36 pieces when 3 pieces cost a total of \$1.50.

1. Enter the deal quantity (1-99), e.g., "3", then press [*X*]. The *X* annunciator will turn on to indicate the scale is in the By-Count mode.
2. Enter the deal price, e.g., "1.50", then press [*FIX*]. The Unit Price display will show "1.50".
3. Enter the quantity to be sold, e.g., "36". The resulting total price of "18.00" is shown in the Total Price display. Keep entering another quantity as needed.
4. To end the By-Count function and return to normal weighing mode, press [*C*].

4.11 Accumulation (Totalize) Function

The Accumulation function is used to add the Total Price of several weighings.

4.11.1 Accumulating

1. Perform a pricing transaction as described in Section 4.6.
2. Press [*+*]. The displayed Total Price is added to the accumulation memory, and the *ADD* and *TOTAL* annunciators will turn on.

3. The Weight display will show “Total”, the Unit Price display will show “T” (the number of weighings), and the Total Price display will show the accumulated Total Price value.
4. Remove the item, then repeat steps 1 and 2 until all desired transactions are finished. The corresponding total number of weighings and accumulated price will be displayed.
5. If using the Pre-pack function (the Unit Price is fixed), press [+] again after step 2 to proceed to the next accumulation.

4.11.2 Recalling and Clearing Accumulation

With the pan empty, press [+]. The accumulated total number of weighings and total price will be displayed. To clear accumulation memory, press [C] at this time. The scale returns to normal weighing mode and the ADD annunciator will turn off.

4.12 Fractional Pricing

If permitted by state law, and with Fractional Pricing enabled in the Service Setup mode accordingly, press [1/2] successively to price in \$ per ½ lb (1/2 annunciator will turn on), \$ per ¼ lb (1/4 annunciator will turn on), return to normal Unit Price mode.

To enable Fractional Pricing in the Service Setup mode:

1. Perform Step 1 in Section 6.1.
2. “SI OFF” is displayed momentarily. Press [PLU] [5] [5] [5] [5] [5].
3. “SCZ” is displayed. Press [FIX].
4. “Step 1” is displayed. Press [FIX] successively to move through parameters Step 1 to 18*.
5. When “Step 18 OFF” is displayed (this parameter enables ¼ lb pricing), press [>T<] to change the setting to “on”, then press [FIX] to proceed to the next parameter.
6. When “Step 19 OFF” is displayed (this parameter enables ½ lb pricing), press [>T<] to change the setting to “on”, then press [PLU] to proceed to “SAVE”.
7. When “SAVE” is displayed, press [FIX] to save changes and restart to weighing mode.



* Note: Do not change the setting of any other parameter unless specified above. Other parameters are service settings intended for authorized servicing use only. If inadvertently changing settings, the scale may be turned off at any time to abort setup without saving any changes.

5. SCALE SETTINGS

5.1 Accessing the User Setup Mode

Press **[PLU]** **[4]** **[4]** **[4]** **[4]**. “oP” will be displayed, then press **[FIX]**.

To navigate in the User Setup Mode:

- Press **[FIX]** to accept the displayed setting and proceed to the next step
- Press **[>T<]** to toggle through available settings
- Press **[>O<]** to return to the previous steps
- Press **[PLU]** to end setup and proceed to “Save”

5.2 User Setup Parameters

Window Display		Description	Available Settings
Weight	Unit Price		
oP	STEP 1	Key-press beeper	ON : Enables this function OFF : Disables this function
	STEP 2	Sleep / Automatic Power-off (battery operation only)	0 : Sleep mode disabled / Auto-off disabled 1 : Sleep mode disabled / Auto-off after 30 min. 2 : Sleep mode after 5 min. / Auto-off disabled 3 : Sleep mode after 5 min. / Auto-off after 30 min. 4 : Sleep mode after 15 min. / Auto-off disabled 5 : Sleep mode after 15 min. / Auto-off after 30 min.
	STEP 3	Automatic clearing of tare and unit price	ON : Auto-clear when weight is removed from the pan OFF : Manual clear by pressing [C]
	STEP 4	Pre-pack (Fix) Mode	ON : Enables this function OFF : Disables this function
	STEP 5	Auto PLU	ON : Search PLU automatically OFF : Search PLU after pressing [PLU]
	STEP 6	1 or 2 PLU's per M-key	ON : 2 PLU's can be stored per M-key OFF : Only 1 PLU can be stored per M-key
	STEP 7	Filtering level	0 : No filtering 1 : Low (faster display speed) 2 : Normal 3 : High
	STEP 8	Communication	0, 1, 2, 3 (not applicable; do not change)
SAVE		Save or Abort	Save : Saves changes and restarts to weighing mode Abort : Restarts to weighing mode without saving changes

Note: **Bold** settings are defaults.

6. CALIBRATION AND SEALING

6.1 Calibration

For best results, calibrate the scale at regular intervals. Temperature changes, geographic gravity variations, altitude changes and abuse are few reasons why a scale may need recalibration.

Note: The following procedure requires the use of hand tools and calibration weights. If unable to perform the calibration, contact an authorized Ohaus service organization.

1. With the scale on, remove any sticker or sealing screw (1), then gently press the switch inside the access hole. A narrow screwdriver may be inserted through the hole to press the switch.

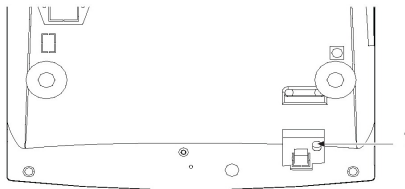

 *Note:* When accessing the bottom of the scale, avoid placing the scale upside down on the pan or sub-platform. Place the scale on its side.

2. “*SI off*” is displayed momentarily. Press [*PLU*] [*2*] [*4*] [*6*] [*8*] [*1*] [*3*].
3. “*SE*” is displayed. Press [*FIX*] successively to move through the succeeding parameters: “*GEo*”, “*SingLE*”, “*CAL n*”.

 *Note:* Press [*>0<*] at any time to return to the previous parameter, or the scale may be turned off at any time to abort setup without saving any changes.

4. When “*CAL n*” is displayed, press [*>T<*] to change the setting to “*CAL Y*”.
5. When “*CAL Y*” is displayed, press [*FIX*] to enter the Span Calibration sequence.

6. Span Calibration Sequence:

Display	Description	Actions
Lb	Calibration Unit: kg or lb	Press [FIX] to select desired unit and proceed to the next step. If needing to switch between kg and lb, press [><T<].
CRP 30	Scale Capacity (in the Calibration Unit selected)	Press [FIX] to select the displayed setting and proceed to the next step. Make sure the displayed value matches the scale model's capacity. Do not press [>>T<], which will toggle through other capacity settings that may not match the scale model's.
-----	Establish zero	Ensure the pan is empty and the scale stable. Press [FIX] to initiate countdown sequence.
5 ... 0	Countdown	The countdown will repeat if the scale is not stable during this process.
Add20	2/3 calibration point	Press [>>T<) to switch between 2/3 or full capacity, then <i>Place the indicated weight on the pan</i> , then press [FIX] to proceed to the next step.
5 ... 0	Countdown	The countdown will repeat if the scale is not stable during this process.
SAVE	Save or Abort	<i>Remove the weight from the pan</i> , then press [FIX] to save settings and restart scale to weighing mode. If needing to abort calibration and retain previous calibration data, press [>>T<) ("Abort" will be displayed) then [FIX] at this time (or turn the scale off at any time during the process).

6.2 Type Approval Sealing

After the scale has been found to comply with local regulations by respective approving authorities, the scale may be sealed in the following manner:

6.2.1 Wire Sealing

(1) Install the 2 cross drilled sealing screws securely as illustrated below. Run the wire into the holes, then apply the seal in place.

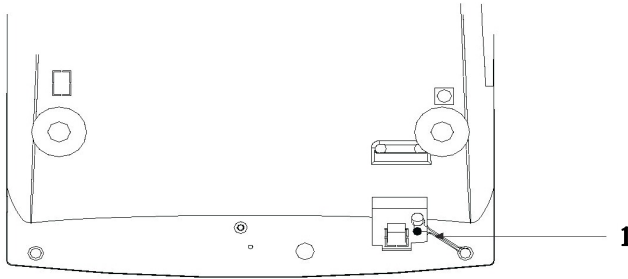

6.2.2 Sticker Sealing

With screws installed, apply stickers to any of the positions illustrated below (2).

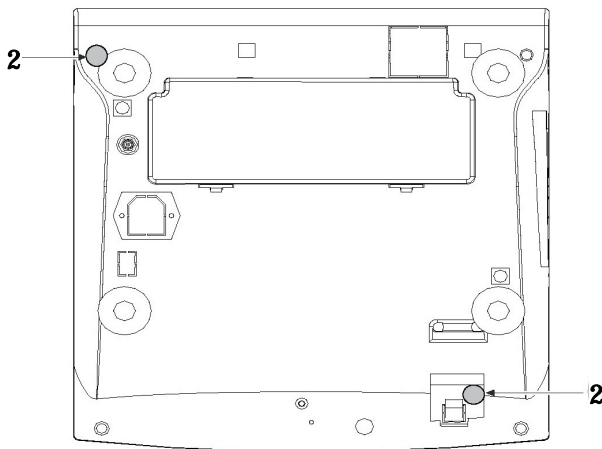

7. MAINTENANCE

7.1 Cleaning



Comply with safety precautions when cleaning and maintaining the scale

- Turn off and disconnect the scale from the power supply during cleaning.
- Wipe the exterior components of the scale using a soft cloth dampened with water and a mild detergent (DO NOT use acids, alkalis, strong solvents or abrasive cleaning agents).
- Inspect the scale regularly. Ensure that the housing, pan and sub-platform are clean and free from foreign material.
- DO NOT allow liquids to enter the scale.
- DO NOT open the scale; no user repairable components inside. Service should be performed by authorized personnel only.
- DO NOT carry the scale by the pan or sub-platform.
- DO NOT place the scale upside down. If accessing the bottom, place the scale on its side.

7.2 Troubleshooting

The following table lists common problems, possible causes and remedies. If the problem persists, contact Ohaus or your authorized Ohaus dealer.

<i>Symptom</i>	<i>Possible Causes</i>	<i>Remedy</i>
Scale will not turn on.	AC power not connected to scale or to outlet. No power in outlet. Battery discharged.	Connect scale to power. Connect to different power outlet. Replace battery.
Weight reading does not stabilize.	Unstable environment. Interference under pan or sub-platform.	Ensure a stable environment. Ensure that the weighing pan and sub-platform are unobstructed.
Scale does not display accurately.	Improper calibration.	Calibrate the scale using proper calibration weights.
----- Weight display	Weight exceeds power-on zero range	Remove excess weight from the pan during power-on.
Weight display	Overload condition	Reduce the load on the pan.
Total Price display	Price > 9999.99	Reduce the load on the pan.
Weight display	Underload condition	Install the pan. Re-zero the scale.
"E 11" displayed	RAM error	Turn the scale off and on again. Return scale for service.
"E 16" displayed	ROM error	Recalibrate the scale. Return scale for service.
"E 18" displayed	EEPROM error	Return scale for service.
"E 31" displayed	By-Count operation error	Enter only up to 2 digits (99)
"E 33" displayed	Accumulation total price > 999.99 or the number of transactions > 99	Clear accumulation memory and start anew
"E 34" displayed	PLU number > 100	Enter correct PLU number: 1-100
"noPLu" displayed	PLU data not found	Store data in the PLU number or M-key

8. TECHNICAL DATA

8.1 Specifications

Model	RE15US	RE30US	RE15CUS
Capacity x Readability	30 lb x 0.01 lb	60 lb x 0.02 lb	30 lb x 0.01 lb
NTEP* Displayed Resolution	3,000d		
Construction	High-grade polymer housing, stainless steel pan		with tower
Pan Dimensions	9.5 x 13.5 in. / 242 x 342 mm		
Leveling Components	4 adjustable rubber feet with integral front mounted level bubble indicator		
Display	Backlit LCD, Weight - Unit Price - Total Price 6-digit, 7-segment, 0.55 in. / 13.5 mm high characters		
	Front and rear		Front and tower
Weighing Units	lb		
Application Modes	100 PLU memory, 24 pre-set keys, By-Count Pricing, Fractional Pricing, Pre-pack Mode, Accumulation		
Keyboard	Numeric, 32-key tactile membrane switch with key-press beeper		
Span Calibration	2/3 and full scale capacity		
Tare Range	To full capacity by subtraction		
Zero Range	At power-on: $\pm 10\%$ / keyboard: $\pm 2\%$ Full Scale Capacity		
Stabilization Time	within 2 seconds		
Power	12VDC 800mA AC Adapter (included) / 6 D-cell alkaline batteries (not included)		
Battery Operation	60~70 hours of continuous use		
Safe Overload	150% Full Scale Capacity		
Operating Temperature Range	14°F to 104°F / -10°C to 40°C		
Storage Temperature Range	-13°F to 122°F / -25°C to 50°C		
Humidity Range	80% max up to 88°F/31°C, decreasing linearly to 50% at 104°F/40°C		
Shipping Dimensions	18.3W x 16.5D x 8.7H in. / 465W x 419D x 221H mm		17.8W x 16.4D x 8.7H in. / 452W x 417D x 221H mm
Scale Unit Weight	7.8 lb / 3.5 kg		9.0 lb / 4.1 kg
Shipping Weight	12.0 lb / 5.5 kg		13.4 lb / 6.1 kg

* NTEP CC No. 08-058

8.2 Drawings

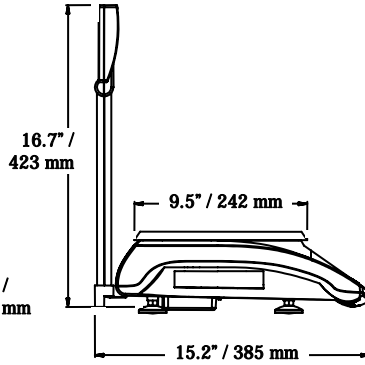
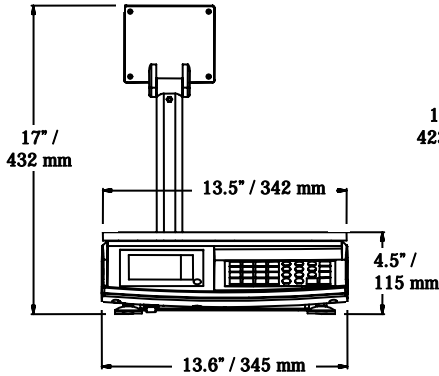
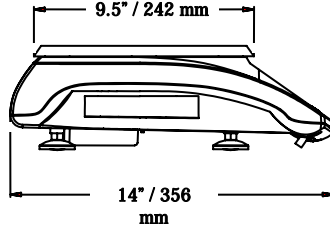
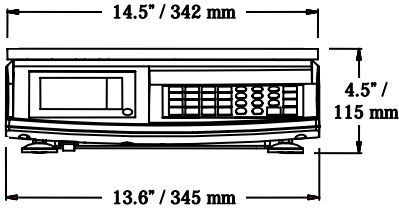

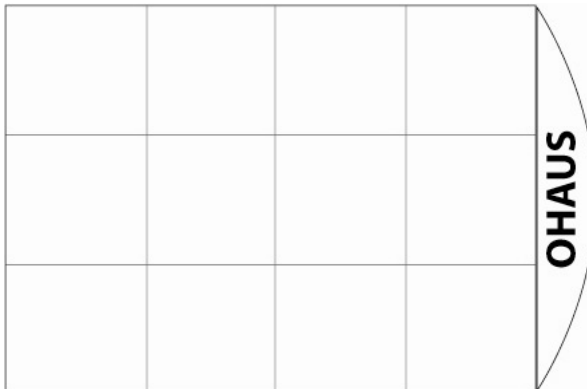

Memory Keys Pull-out Tab Template:





8.3 Compliance

Compliance to the following standards is indicated by the corresponding mark on the product.

Marking	Standard
	This product conforms to the EMC directive 2004/108/EC, the Low Voltage Directive 2006/95/EC and the Non-automatic Weighing Instruments Directive 90/384/EEC. The complete Declaration of Conformity is available from Ohaus Corporation.
	UL60950-1: 2003

EC Emissions Note

This device complies with EN61326/CISPR 11 Class B Group 1.

 	<p><i>Disposal</i></p> <p>In conformance with the European Directive 2002/96/EC on Waste Electrical and Electronic Equipment (WEEE) this device may not be disposed of in domestic waste. This also applies to countries outside the EU, per their specific requirements.</p> <p>Please dispose of this product in accordance with local regulations at the collecting point specified for electrical and electronic equipment.</p> <p>If you have any questions, please contact the responsible authority or the distributor from which you purchased this device.</p> <p>Should this device be passed on to other parties (for private or professional use), the content of this regulation must also be related.</p> <p>Thank you for your contribution to environmental protection.</p> <p>For disposal instructions in Europe, refer to www.ohaus.com/weee.</p>
--	--

FCC Note

This equipment has been tested and found to comply with the limits for a Class B digital device, pursuant to Part 15 of the FCC Rules. These limits are designed to provide reasonable protection against harmful interference when the equipment is operated in a commercial environment. This equipment generates, uses, and can radiate radio frequency energy and, if not installed and used in accordance with the instruction manual, may cause harmful interference to radio communications. Operation of this equipment in a residential area is likely to cause harmful interference, in which case the user will be required to correct the interference at their own expense.

Industry Canada Note

This Class B digital apparatus complies with Canadian ICES-003.
 Cet appareil numérique de la classe B est conforme à la norme NMB-003 du Canada.

ISO 9001 Registration

In 1994, Ohaus Corporation, USA, was awarded a certificate of registration to ISO 9001 by Bureau Veritas Quality International (BVQI), confirming that the Ohaus quality management system is compliant with the ISO 9001 standard's requirements. On May 15, 2003, Ohaus Corporation, USA, was re-registered to the ISO 9001:2000 standard.

LIMITED WARRANTY

Ohaus products are warranted against defects in materials and workmanship from the date of delivery through the duration of the warranty period. During the warranty period, Ohaus will repair, or, at its option, replace any component(s) that proves to be defective at no charge, provided that the product is returned, freight prepaid, to Ohaus.

This warranty does not apply if the product has been damaged by accident or misuse, exposed to radioactive or corrosive materials, has foreign material penetrating to the inside of the product, or as a result of service or modification by other than Ohaus. In lieu of a properly returned warranty registration card, the warranty period shall begin on the date of shipment to the authorized dealer. No other express or implied warranty is given by Ohaus Corporation. Ohaus Corporation shall not be liable for any consequential damages.

As warranty legislation differs from state to state and country to country, please contact Ohaus or your local Ohaus dealer for further details.



Ohaus Corporation
19A Chapin Road
P.O. Box 2033
Pine Brook, NJ 07058, USA
Tel: (973) 377-9000
Fax: (973) 593-0359

With offices worldwide

www.ohaus.com



P/N 80252577 © 2008 Ohaus Corporation, all rights reserved

Printed in China